

Experiência de bomba

Segundo
semestre de
2014

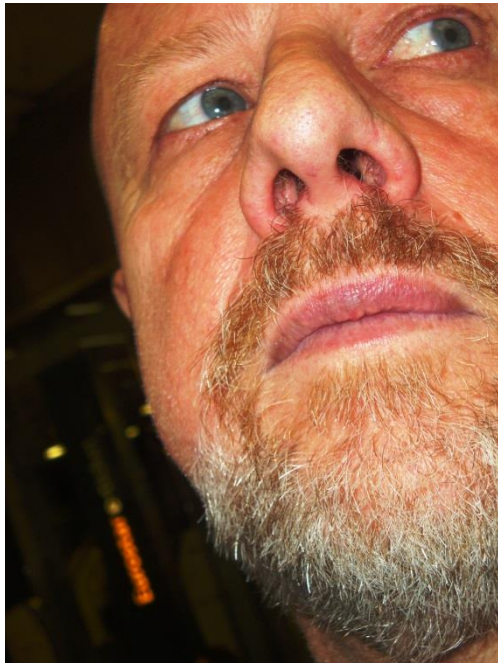

Bancadas
de 1 a 6



Bancada
7



Objetivos desta experiência: obter a curva $H_B = f(Q)$ para a rotação de 3500 rpm e compará-la com a fornecida pelo fabricante e obter a curva do $\eta_{\text{global}} = f(Q)$.





exercícios resolver



Evocar

- a determinação direta da vazão
- uma instalação de recalque
- a determinação da carga total de uma seção do escoamento incompressível e em regime permanente
- como a perda de carga é considerada entre a entrada e saída de uma bomba
- a determinação da carga manométrica da bomba
- conceitos de potências do conjunto motobomba
- conceitos de rendimentos do conjunto motobomba
- conceito de modelo
- conceito de protótipo
- os dimensionais típicos da bomba



obter para protótipo

vazão função carga manométrica
vazão rendimento global

Objetivos da experiência de bomba hidráulica

29/10/2008 - v12



obter para modelo

vazão
carga manométrica
potência útil
potência consumida
rendimento global



Exemplo para o protótipo

3500 rpm rotação
portanto devemos corrigir

$\frac{Q}{HB}$

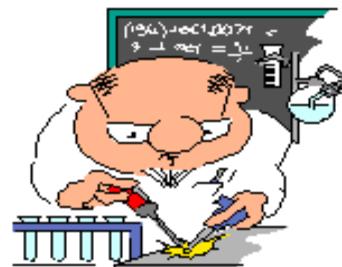

Exemplo para modelo

rotação lida
rotor Dr



Nesta experiência a bomba é utilizada em uma instalação de recalque, que é uma instalação particular de bombeamento aonde o fluido é bombeado de uma cota inferior para uma cota superior.

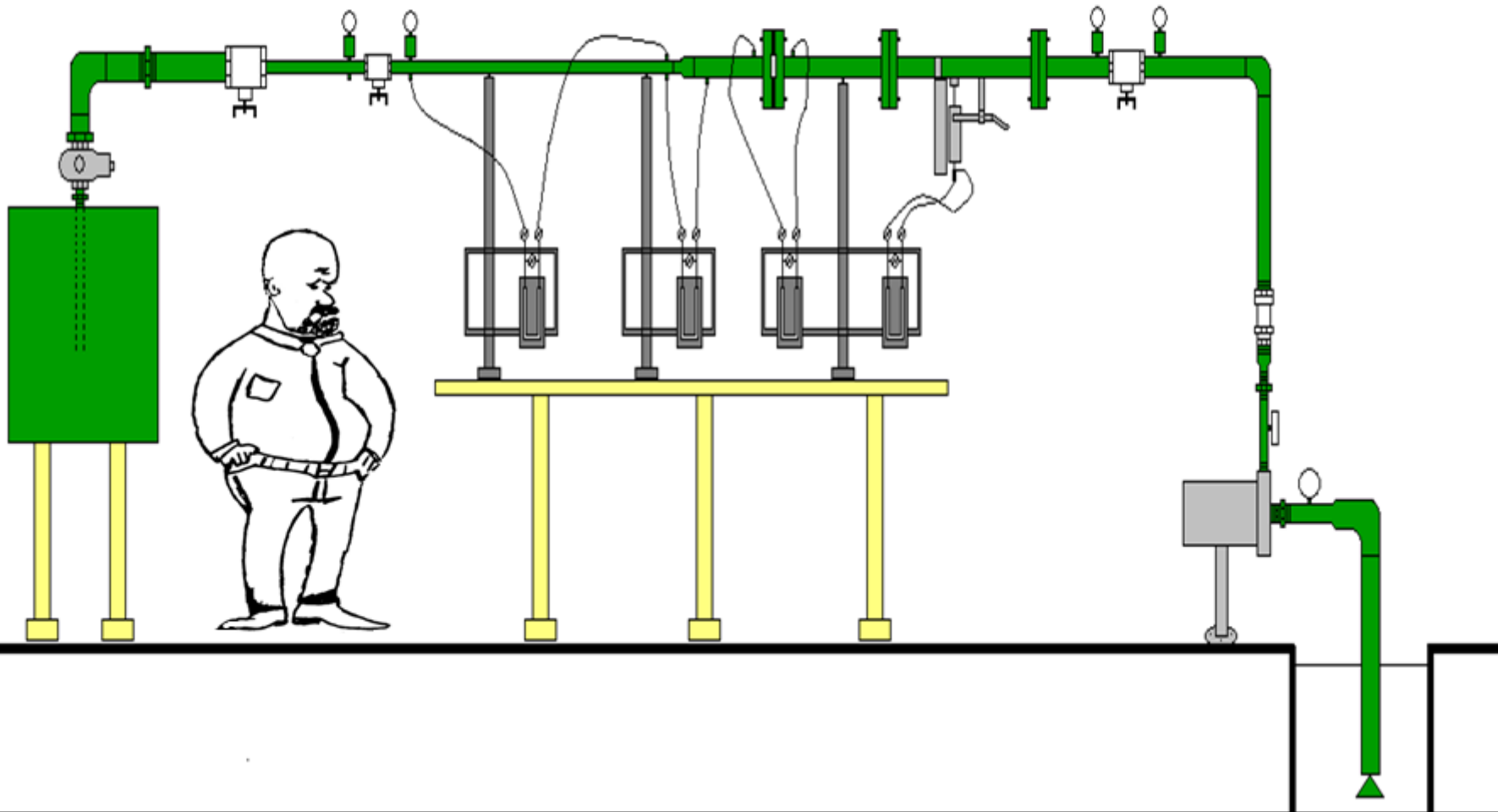

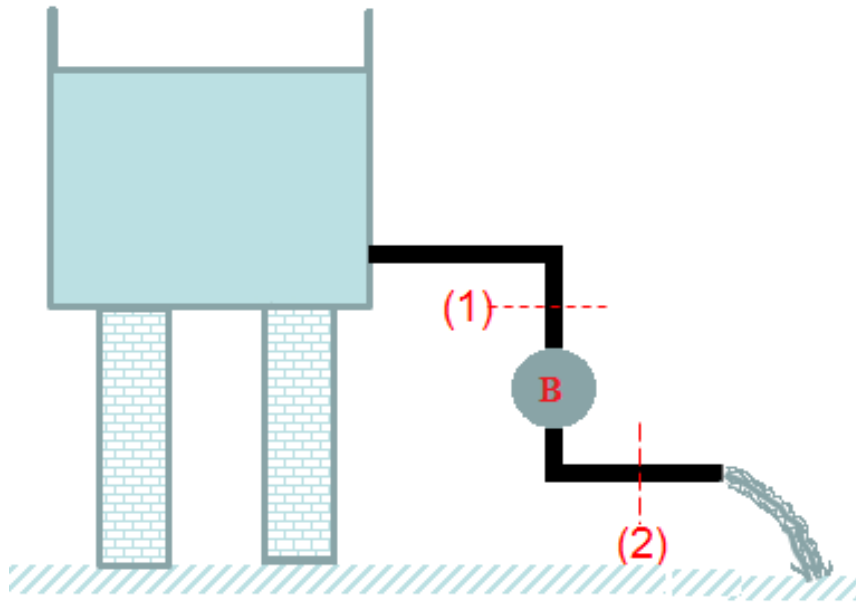

$$H_1 = z_1 + \frac{p_1}{\gamma} + \frac{\alpha_1 \times v_1^2}{2g}$$

$$H_2 = z_2 + \frac{p_2}{\gamma} + \frac{\alpha_2 \times v_2^2}{2g}$$

$$H_1 + H_B = H_2 + H_{p1-2}$$

O único trecho que a perda não entra na equação anterior é a entrada e saída da máquina, isto porque já é considerado no rendimento

Determinação da
carga
manométrica



$H_{\text{inicial}} + H_B = H_{\text{final}} + H_{p_{i-f}} \therefore H_{\text{entrada}} + H_B = H_{\text{saida}}$
não se leva em conta a perda porque ela já é considerada
no rendimento da bomba

$$Z_e + \frac{p_e}{\gamma} + \frac{v_e^2}{2g} + H_B = Z_s + \frac{p_s}{\gamma} + \frac{v_s^2}{2g}$$

PHR na entrada da bomba



Determinação das
cargas potenciais.



Se o mesmo for adotado no eixo da
bomba, tem-se:

$$Z_e = 0$$

$$Z_s = \text{medido}$$



Determinação das cargas de pressão através das leituras das pressões e para isto temos:



- vacuômetro (poderia ser também um manovacuômetro) na seção de entrada = p_{me} ;
- manômetro na seção de saída = p_{ms}



Cuidado $p_{ms} \neq p_s$





EXISTEM
DIFERENÇAS!



A leitura do aparelho pode ser diferente da pressão que se deseja determinar na seção.

$$P_{\text{seção}} = P_{\text{manométrica}} + \gamma \times h_{\text{correção}}$$

E ela é obtida pelo teorema de Stevin





Para a situação
descrita ao
lado temos:
 $p_e = p_{me} + \gamma * h_e$
e $p_s = p_{ms}$

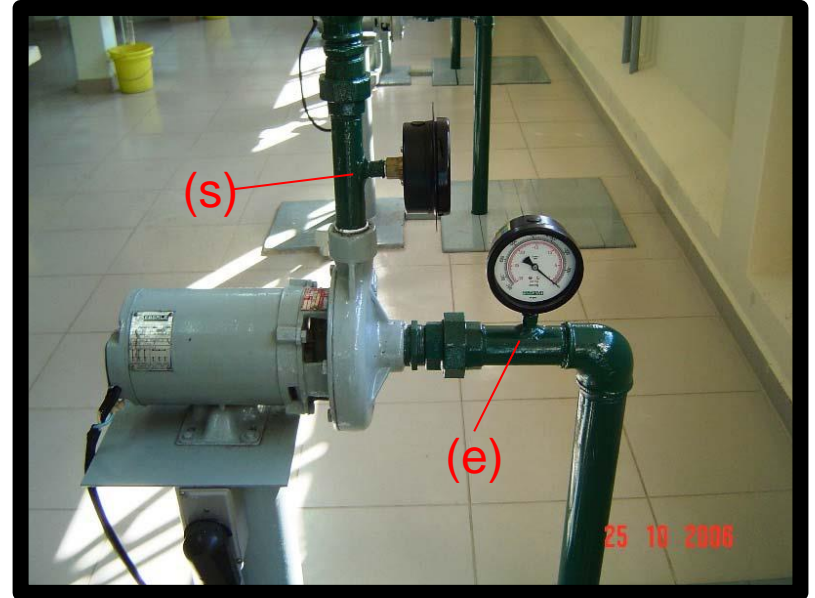

Já na situação
ao lado ambas
as pressões
devem ser
corrigidas!

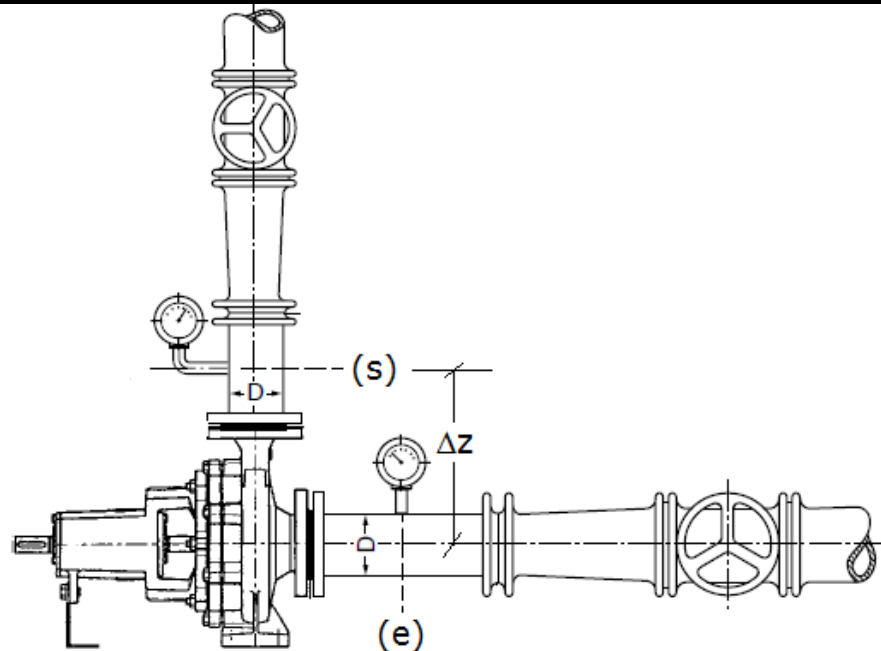

Importante salientar que vamos considerar o coeficiente de energia cinética igual a 1,0 ($\alpha = 1,0$), o que resulta:

$$H_B = (z_s - z_e) + \left(\frac{p_s - p_e}{\gamma} \right) + \left(\frac{v_s^2 - v_e^2}{2g} \right)$$



E como achamos as velocidades?

Com a vazão é possível calcular a velocidade média do escoamento, tanto na seção de entrada, como na seção de saída da bomba, já que:

$$v = \frac{Q}{A} = \frac{4 \times Q}{\pi \times D^2}$$



Portanto, temos H_B e a Q :

$$H_B = (Z_s - Z_e) + \left(\frac{p_s - p_e}{\gamma} \right) + \left(\frac{v_s^2 - v_e^2}{2g} \right) \rightarrow Q = \frac{V}{t}$$

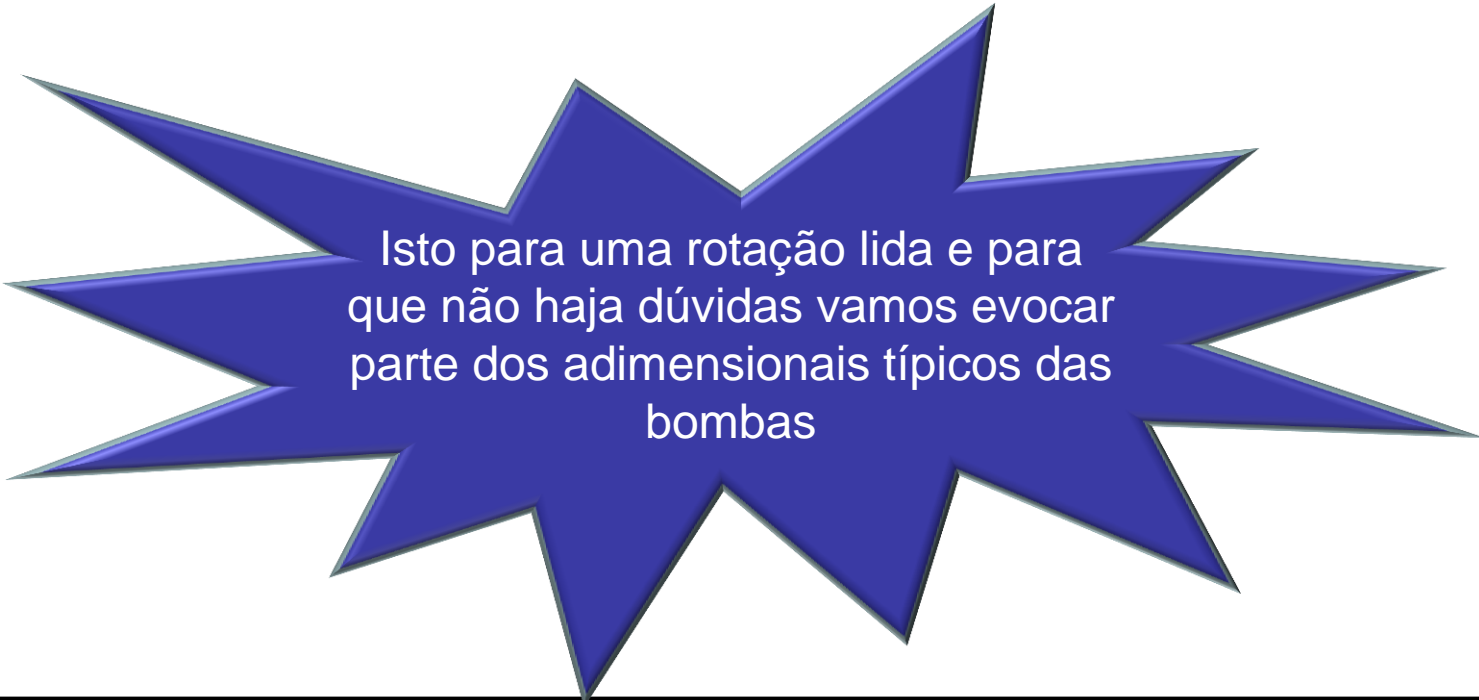

Isto para uma rotação lida e para que não haja dúvidas vamos evocar parte dos adimensionais típicos das bombas

Já que com eles construímos a curva universal e também podemos corrigir H_B e Q para a rotação de 3500 rpm

$$\psi = \frac{g \times H_B}{n^2 \times D_R^2} \rightarrow \text{coeficiente manométrico}$$

$$\phi = \frac{Q}{n \times D_R^3} \rightarrow \text{coeficiente de vazão}$$



Isto mesmo, o coeficiente manométrico – ψ e o coeficiente de vazão - ϕ

E aí lembrar que modelo é o que ensaiamos em laboratório e protótipo é o que desejamos obter informações sem recorrer a ensaios.



Para o modelo temos:

$$\psi_m = \frac{g \times H_B}{n^2 \times D_r^2} = \frac{9,8 \times H_{B_{\text{exp}}}}{\left(\frac{n_{\text{lida}}}{60}\right)^2 \times (D_r)^2}$$

$$\phi_m = \frac{Q}{n \times D_r^3} = \frac{Q_{\text{exp}}}{\left(\frac{n_{\text{lida}}}{60}\right) \times (D_r)^3}$$

O modelo tem as rotações lidas e o protótipo a rotação de 3500 rpm. Pelas condições de semelhança, corrigimos tanto a vazão, como a carga manométrica obtidas para a rotação de 3500 rpm, o que possibilita comparar as curvas fornecidas pelo fabricante com as obtidas experimentalmente.

$$\frac{Q_{3500}}{3500/60} = \frac{Q_{\text{exp}}}{n_{\text{lida}}/60} \Rightarrow \frac{Q_{3500}}{3500} = \frac{Q_{\text{exp}}}{n_{\text{lida}}}$$

$$\frac{H_{B3500}}{\left(3500/60\right)^2} = \frac{H_{B\text{exp}}}{\left(n_{\text{lida}}/60\right)^2} \Rightarrow \frac{H_{B3500}}{3500^2} = \frac{H_{B\text{exp}}}{n_{\text{lida}}^2}$$



Antes de continuarnos,
vamos mencionar os tipos de
curvas que podemos ter.

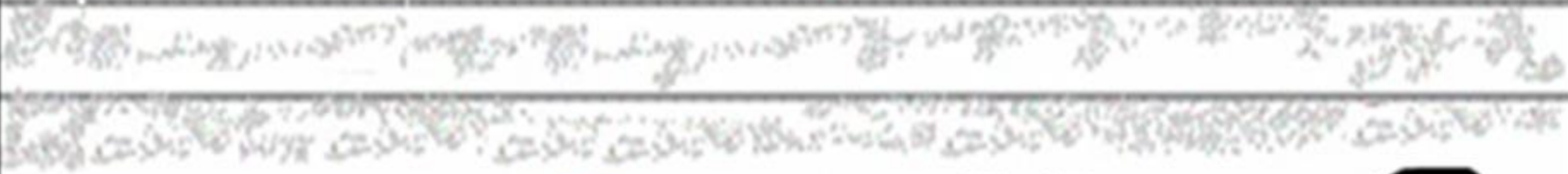

Tipos de curvas de bomba

CURVA TIPO ESTÁVEL OU TIPO RISING

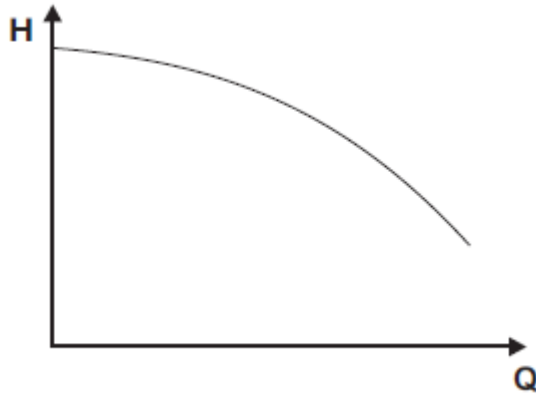

Neste tipo de curva, a altura aumenta continuamente com a diminuição da vazão. A altura correspondente a vazão nula é cerca de 10 a 20% maior que a altura para o ponto de maior eficiência.

CURVA TIPO INSTÁVEL OU TIPO DROOPING

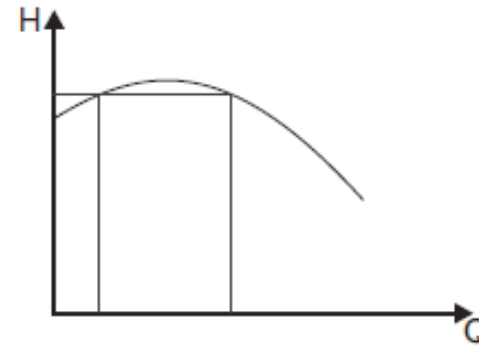

Nesta curva, a altura produzida com a vazão zero é menor do que as outras correspondentes a algumas vazões. Neste tipo de curva, verifica-se que para alturas superiores ao shut-off, dispomos de duas vazões diferentes, para uma mesma altura.

Tipos de curvas de bomba

CURVA TIPO INCLINADO ACENTUADO OU TIPO STEEP

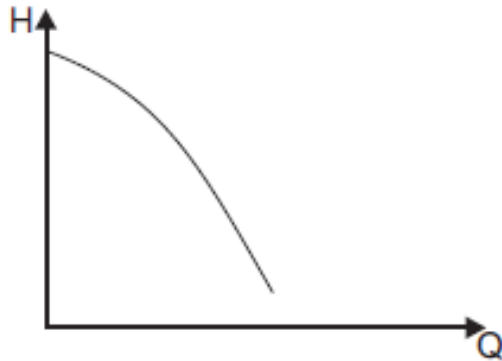

É uma curva do tipo estável, em que existe uma grande diferença entre a altura desenvolvida na vazão zero (shut-off) e a desenvolvida na vazão de projeto, ou seja, cerca de 40 a 50%.

CURVA TIPO PLANA OU TIPO FLAT

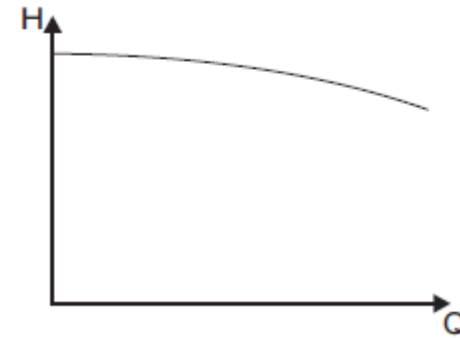

Nesta curva, a altura varia muito pouco com a vazão, desde o shut-off até o ponto de projeto.

Tipos de curvas de bomba

CURVA TIPO INSTÁVEL

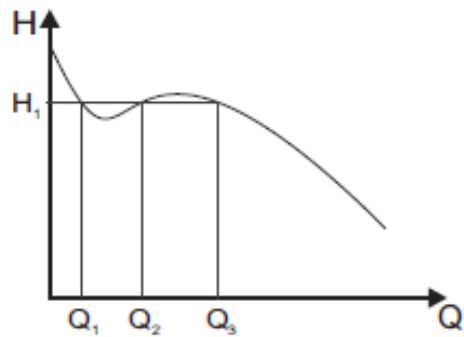

É a curva na qual para uma mesma altura, corresponde duas ou mais vazões num certo trecho de instabilidade. É idêntica a curva drooping.

QUE TIPO
DE CURVA
TEM A
BOMBA
ENSAIADA?



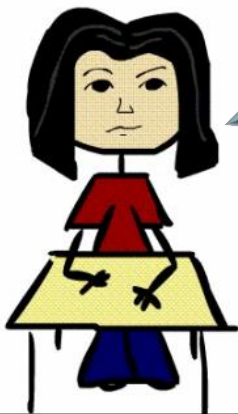
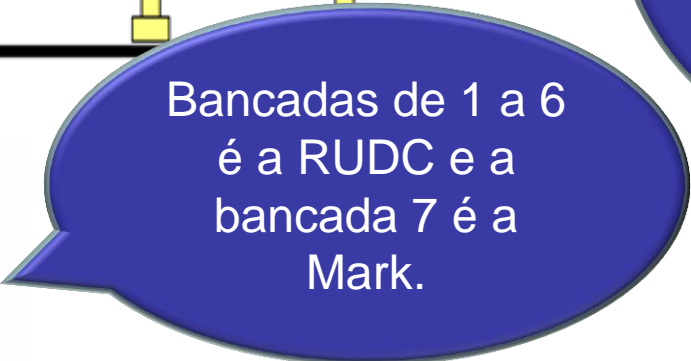
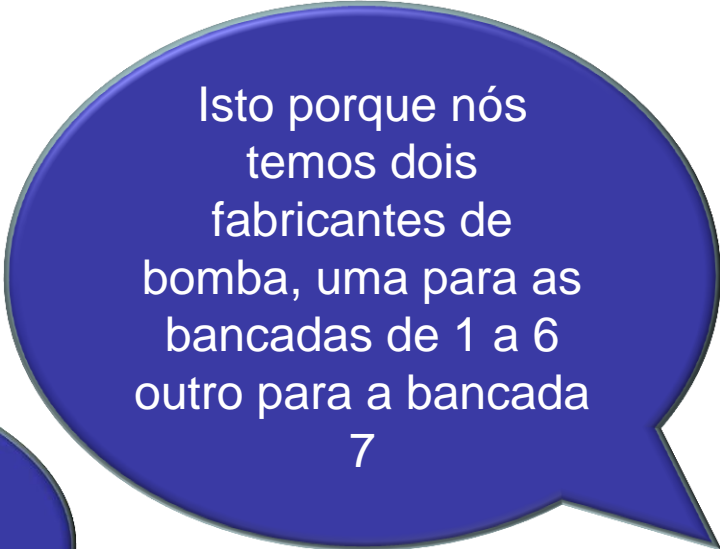
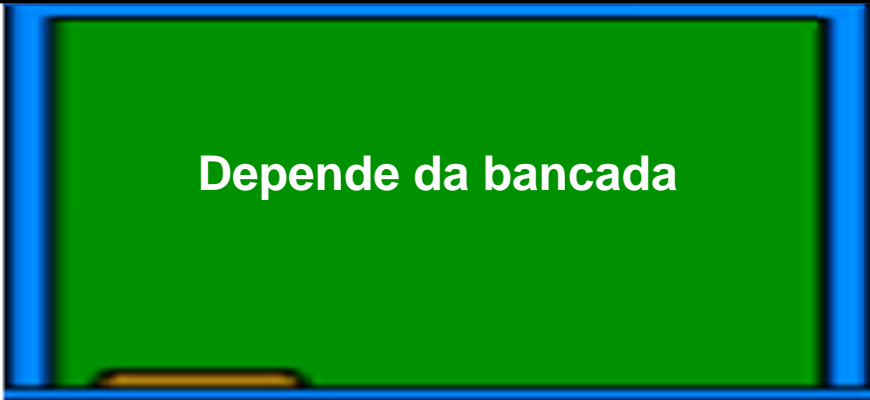
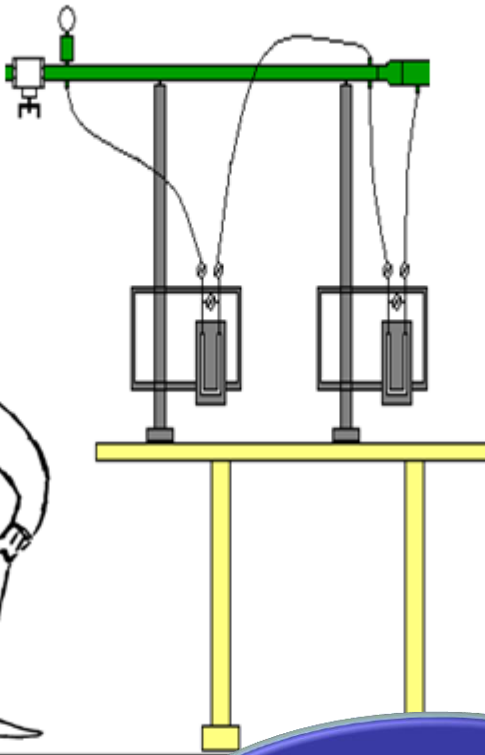

Bancadas 1 a 6



ATENÇÃO

1. Bomba RUDC vedada por selo mecânico. A falta de água provoca a quebra do selo. Somente acionar quando preenchida com água limpa.
2. A ligação elétrica deve ser feita por electricista competente utilizando condutores corretamente dimensionados.
3. Sentido de rotação: anti-horário obrigatório conforme a seta.
4. Usar bitolas da tubulação indicadas no manual.
5. Para água suja ou produtos químicos, consultar fábrica.

RUDC IND. E COM. LTDA

RUDC

3

Apresentando as curvas da
bomba fornecida pelo seu
fabricante

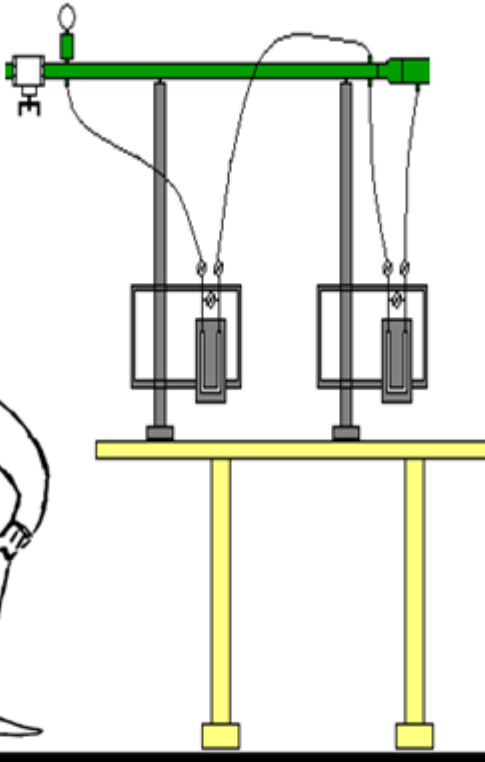

Bancadas 1 a 6
temos a RUDC RF5
de 1,5CV

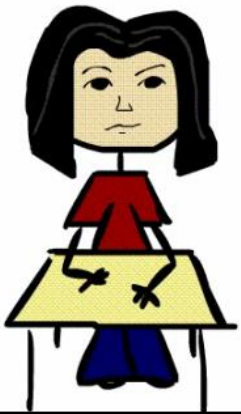



RUDC INDÚSTRIA E COMÉRCIO LTDA

3500 RPM - LINHA RF

Curvas da bomba para as bancadas de 1 a 6

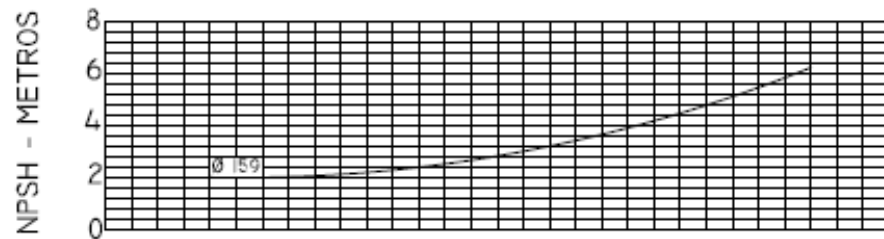
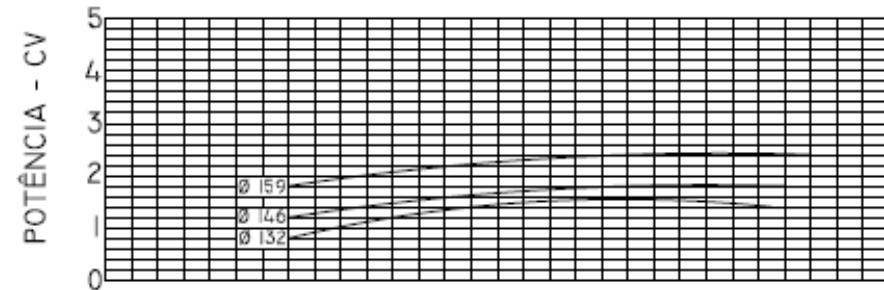
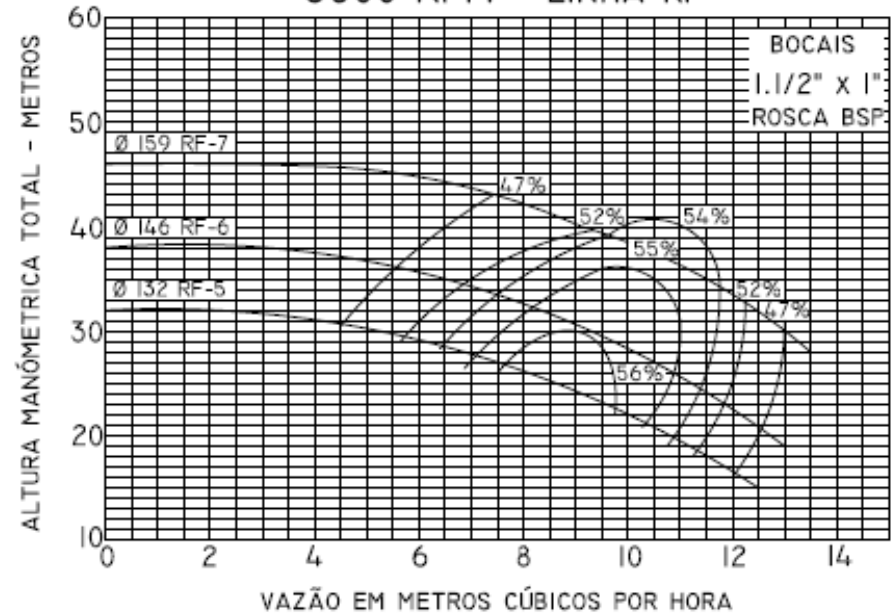



RUDC INDUSTRIA E COMERCIO LTDA

3500 RPM - LINHA RF

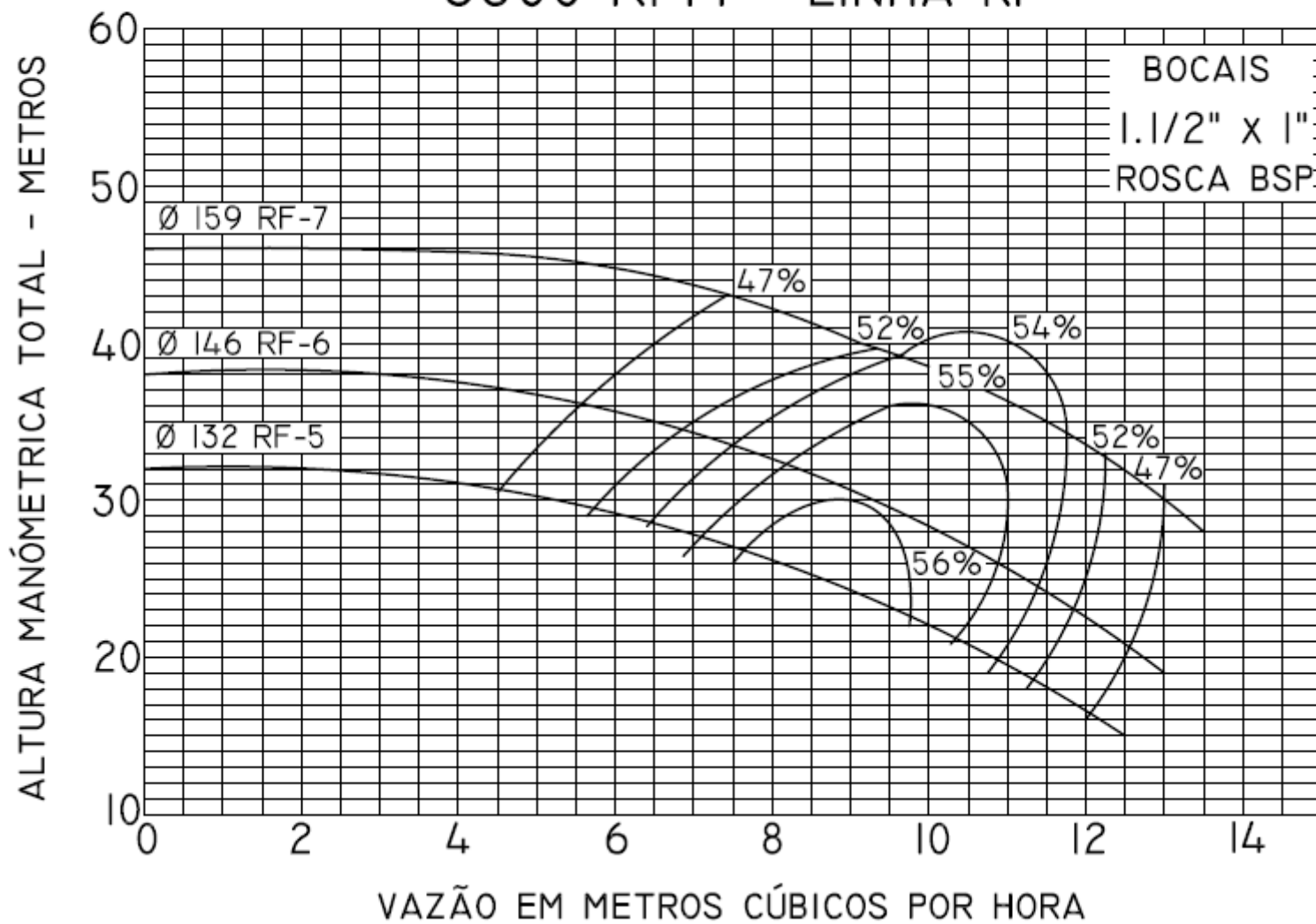

0 2 4 6 8 10 12 14

VAZÃO EM METROS CÚBICOS POR HORA

POTÊNCIA - CV

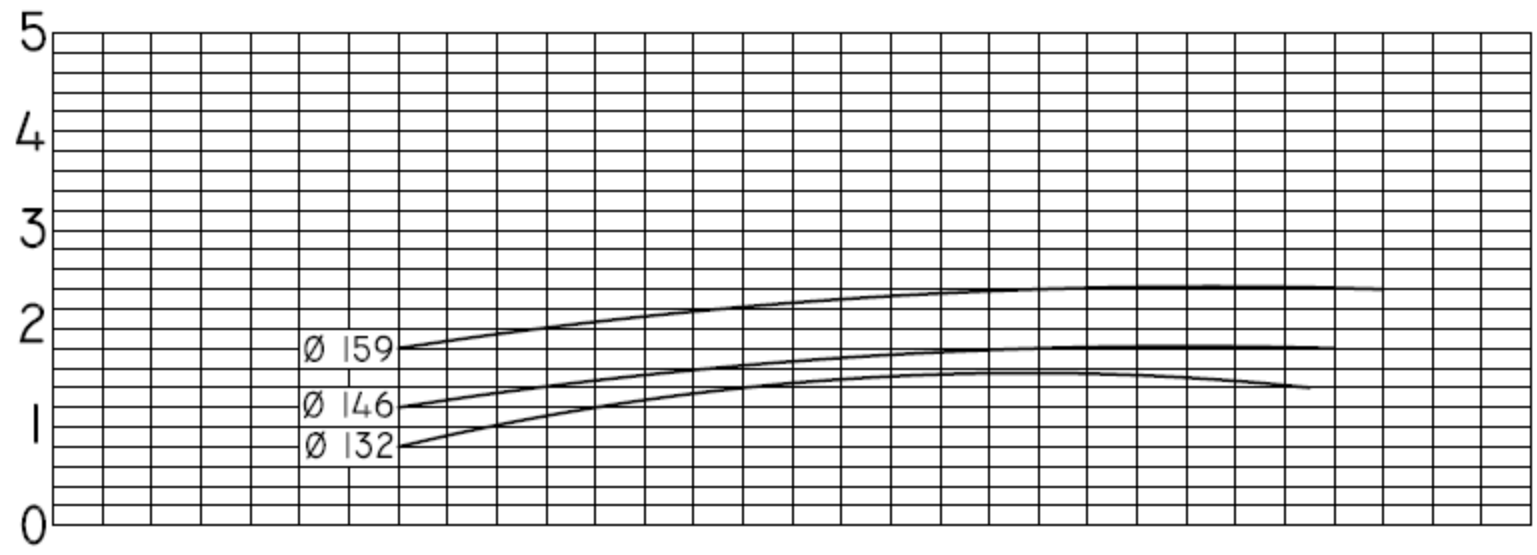

NPSH - METROS

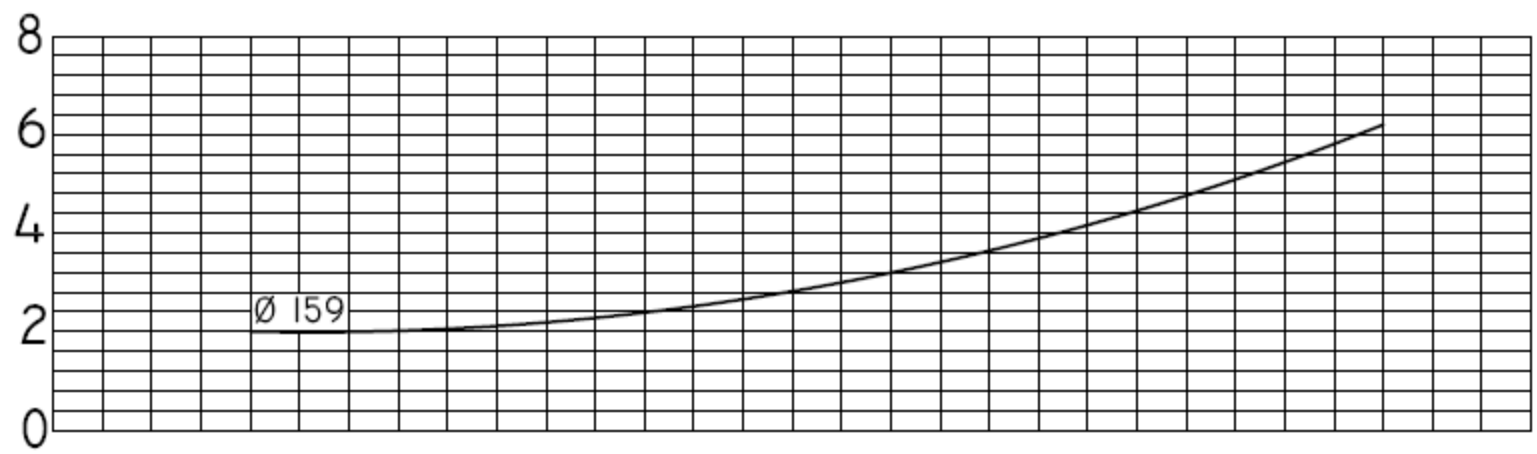

Bancada 7



GRUNDFOS

MARK

IND. BRASILEIRA

CNPJ

02.599.337/0001-92

S. BERNARDO DO CAMPO-SP

CÓDIGO

NDF-6

FABRICAÇÃO

07/12

POTÊNCIA

2

CV

3 500 rpm

000202E

76 74 75

71 72 73

Apresentando as curvas da
bomba fornecida pelo seu
fabricante

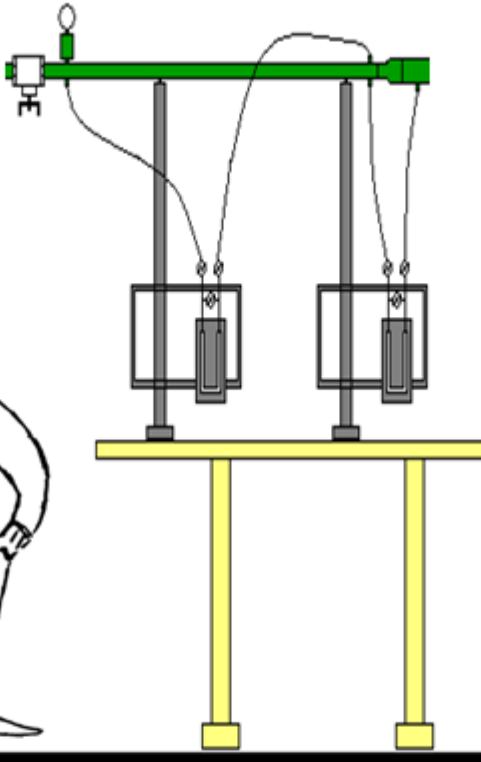

Bancada 7 a
GRUNDFOS MARK
NDF-6 de 2 CV

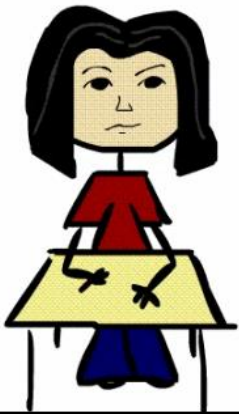

		MARK GRUNDFOS LTDA.					MODELO DF	
		Bomba Centrífuga Monoestágio					RPM 3.500	
Rotor	146	mm	Número de estágios	1	Sucção	Recalque	Válido para água limpa a 20 C.	
Ponto de trabalho					1.1/2"	1"		
Q		Hm			Vedação	Roscas		
cv		%			Selo mecânico	BSP		

Curvas da bomba para as bancadas de 7 e 8



Testes e Aceleração conforme Norma ISO 9906:1999 Anexo A

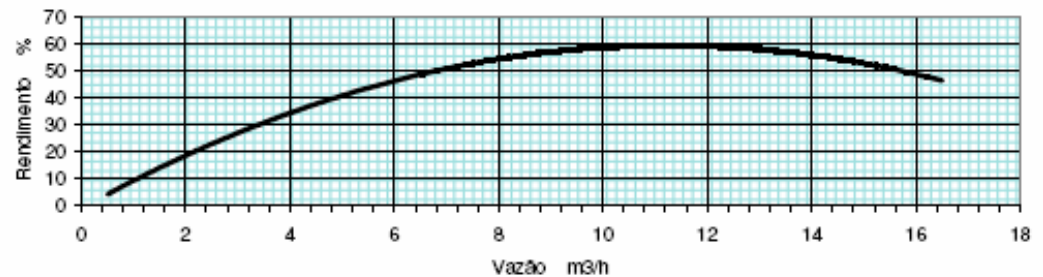
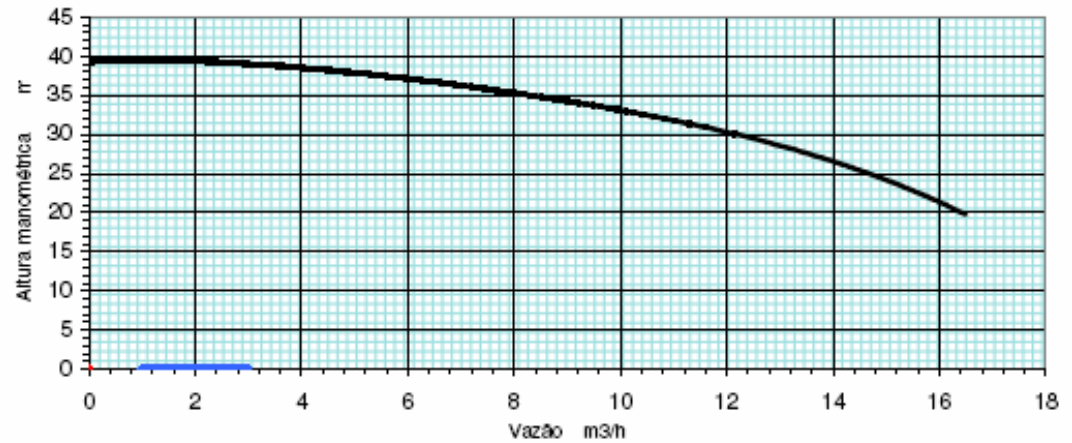



Observem que as curvas do rendimento estão representadas de forma diferente e nesta experiência objetivamos obter a representação similar a fornecida pela GRUNDFOS MARK, porém é importante compreender como saindo desta representação chegamos a uma similar à fornecida pela RUDC

OBSERVEM COMO SÃO
GERALMENTE
REPRESENTADOS OS
RENDIMENTOS PELOS
FABRICANTES (CURVAS
DE ISORENDIMENTOS)

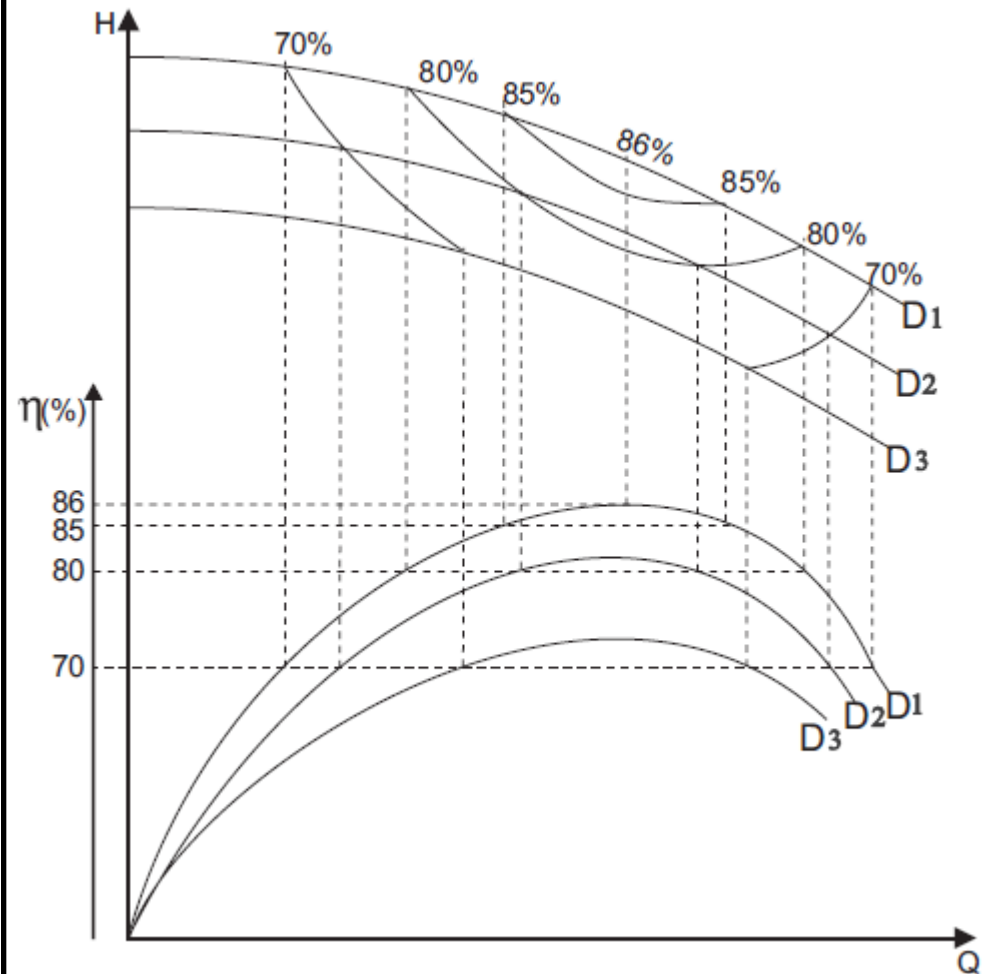



Importante ainda notar que nesta experiência não conseguimos obter o rendimento da bomba (η_B) e por este motivo iremos considerar o rendimento global e aí o nosso gráfico será o rendimento global em função da vazão
($\eta_{\text{global}} = f(Q)$)

No intuito de eliminar dúvidas, vamos evocar alguns conceitos:

Conceito de motor, bomba, potências e rendimentos

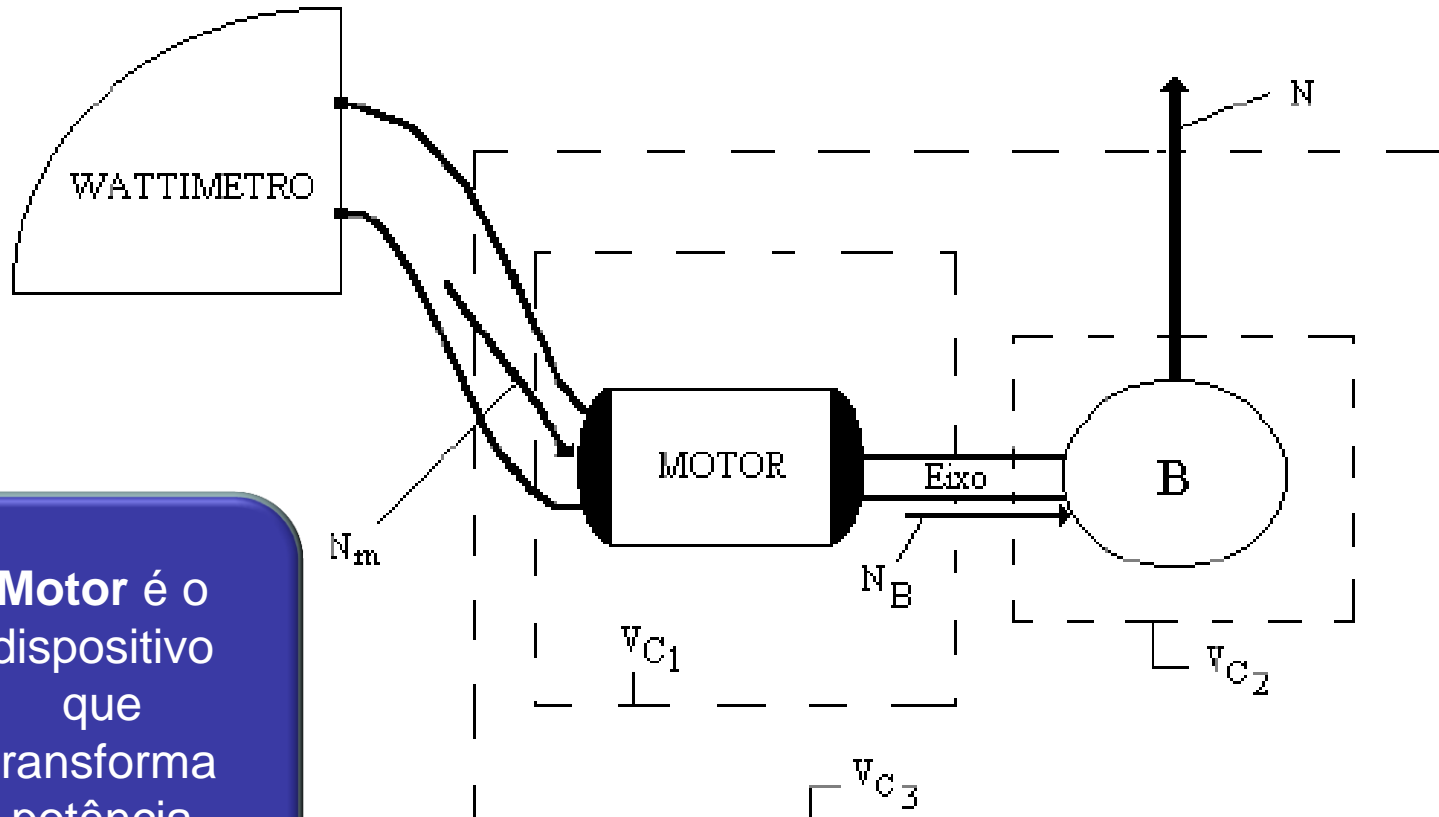

Motor é o dispositivo que transforma potência elétrica em mecânica

Bomba é o dispositivo que transforma potência mecânica em potência hidráulica

Conceito de rendimento:

$$\eta_{VC} = \frac{\text{potência que sai}}{\text{potência que entra}}$$

$$\eta_{\text{motor}} = \frac{N_B}{N_m}$$

$$\eta_{\text{bomba}} = \eta_B = \frac{N}{N_B} = \frac{\gamma \times Q \times H_B}{N_B}$$

$$\eta_{\text{global}} = \frac{N}{N_m} = \frac{\gamma \times Q \times H_B}{N_m}$$



Exatamente!

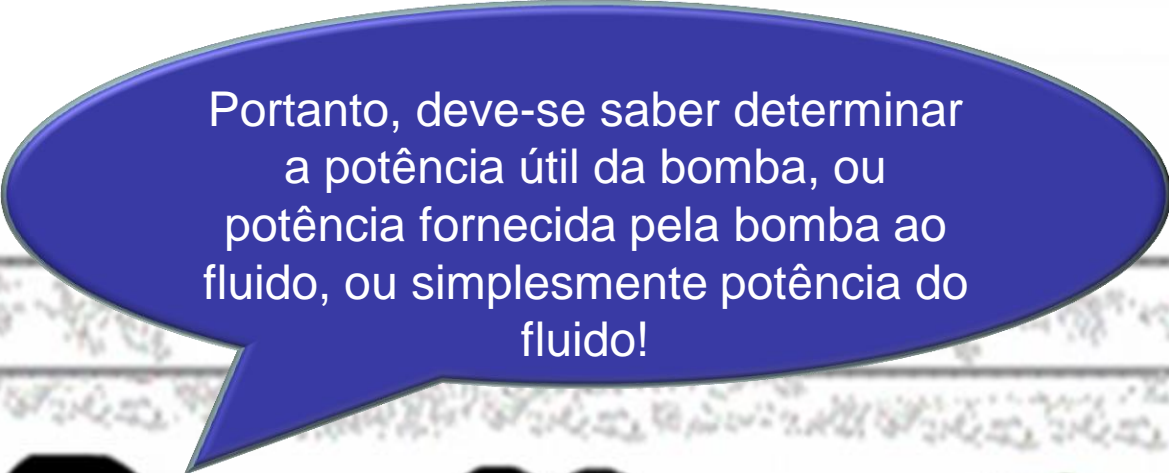

Portanto, deve-se saber determinar a potência útil da bomba, ou potência fornecida pela bomba ao fluido, ou simplesmente potência do fluido!

Determinação de N

$$H_B = \frac{\text{energia fornecida pela bomba ao fluido}}{\text{peso do fluido}} = \frac{E}{G}$$

$$\therefore E = G \times H_B = \gamma \times V \times H_B$$

$$\frac{E}{t} = N = \frac{\gamma \times V \times H_B}{t} = \gamma \times Q \times H_B$$

$$\text{Se } [\gamma] = \frac{\text{kgf}}{\text{m}^3} \rightarrow [Q] = \frac{\text{m}^3}{\text{s}} \rightarrow [H_B] = \text{m} \therefore [N] = \frac{\text{kgf} \times \text{m}}{\text{s}}$$

$$1\text{CV} = 75 \frac{\text{kgf} \times \text{m}}{\text{s}} = 75 \times 9,8 \frac{\text{N} \times \text{m}}{\text{s}} (\text{ou } w) = \frac{75 \times 9,8}{1000} \text{kw}$$



Voltando aos objetivos
ressalto que desejamos
determinar a curva $H_B = f(Q)$
para a rotação de 3500 rpm.

Isto porque o fabricante forneceu sua curva a 3500 rpm.



		MARK GRUNDFOS LTDA.					MODELO DF	
Rotor	146	mm	Número de estágios	1	Sucção	Recalque	RPM 3.500	
Ponto de trabalho					1.1/2"	1"	Válido para água limpa a 20 C.	
Q		Hm			Vedação	Roscas		
cv		%			Selo mecânico	BSP		

Testes e Aceleração conforme Norma ISO 9906:1999 Anexo A

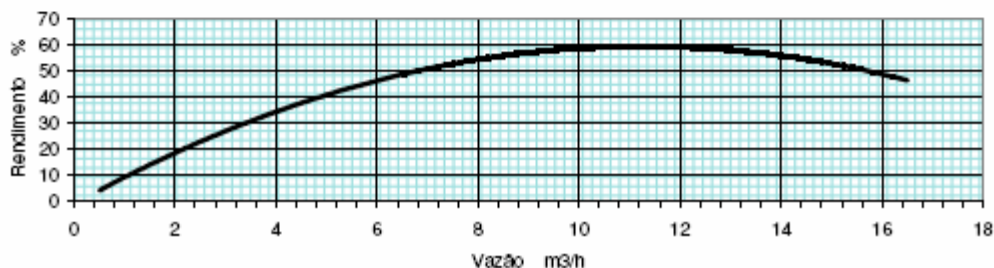
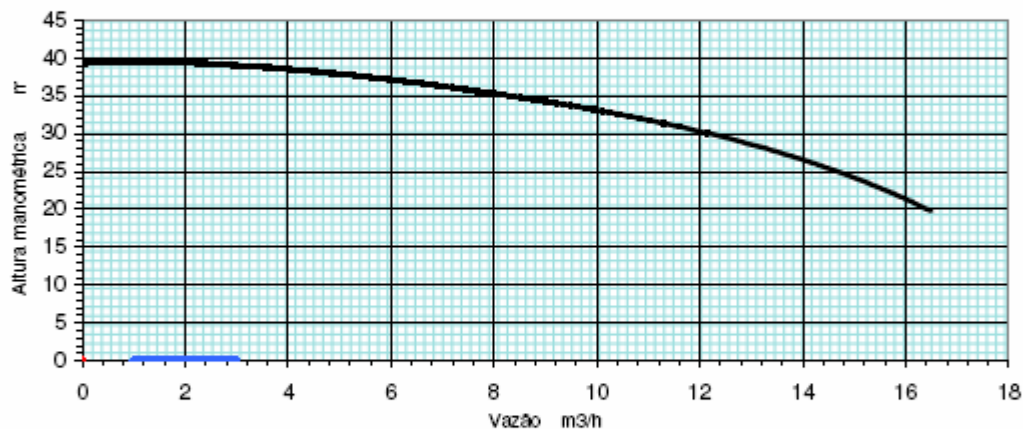



Vamos a partir daqui
mencionar os dados
que devem ser
obtidos.



As pressões manométricas de entrada e saída





A rotação para cada vazão considerada.



Leitura da rotação (n_{lida})





O tempo para obter o Δh estabelecido (ex. 100 mm).



Para cada vazão, no intuito de calcular o rendimento global, devemos também ler a potência consumida da rede pelo conjunto do motor e bomba através do wattímetro como mostrado ao lado.



Com as leituras anteriores,
criamos a tabela de dados a
seguir:



Tabela de dados:

N_m (kw)	n (rpm)	p_{me} (mmHg ou bar)	p_{ms} (kPa)	Δh (mm)	t (s)

$$A_{\text{tanque}} = \dots \rightarrow \Delta z = z_s - z_e = \dots$$

$$t_{\text{água}} = \dots$$

$$h_{\text{entrada}} = \dots \rightarrow D_{\text{intentrada}} = \dots$$

$$h_{\text{saída}} = \dots \rightarrow D_{\text{intsaída}} = \dots$$

$$g = \dots$$

Já a tabela de resultados, os cálculos de uma de suas linhas e os gráficos devem ser criados pela equipe em função da bancada destinada a ela.



Exercícios

1

Conhecendo-se a curva universal da bomba da instalação da figura, e sabendo-se que o tanque enche em 200 s a partir de vazio, determinar a leitura do manômetro de saída da bomba. Dados: $p_{me} = -1,5 \text{ mca}$; $n = 3450 \text{ rpm}$; $D_r = 126 \text{ mm}$; $g = 9,8 \text{ m/s}^2$; $D_e = D_s$

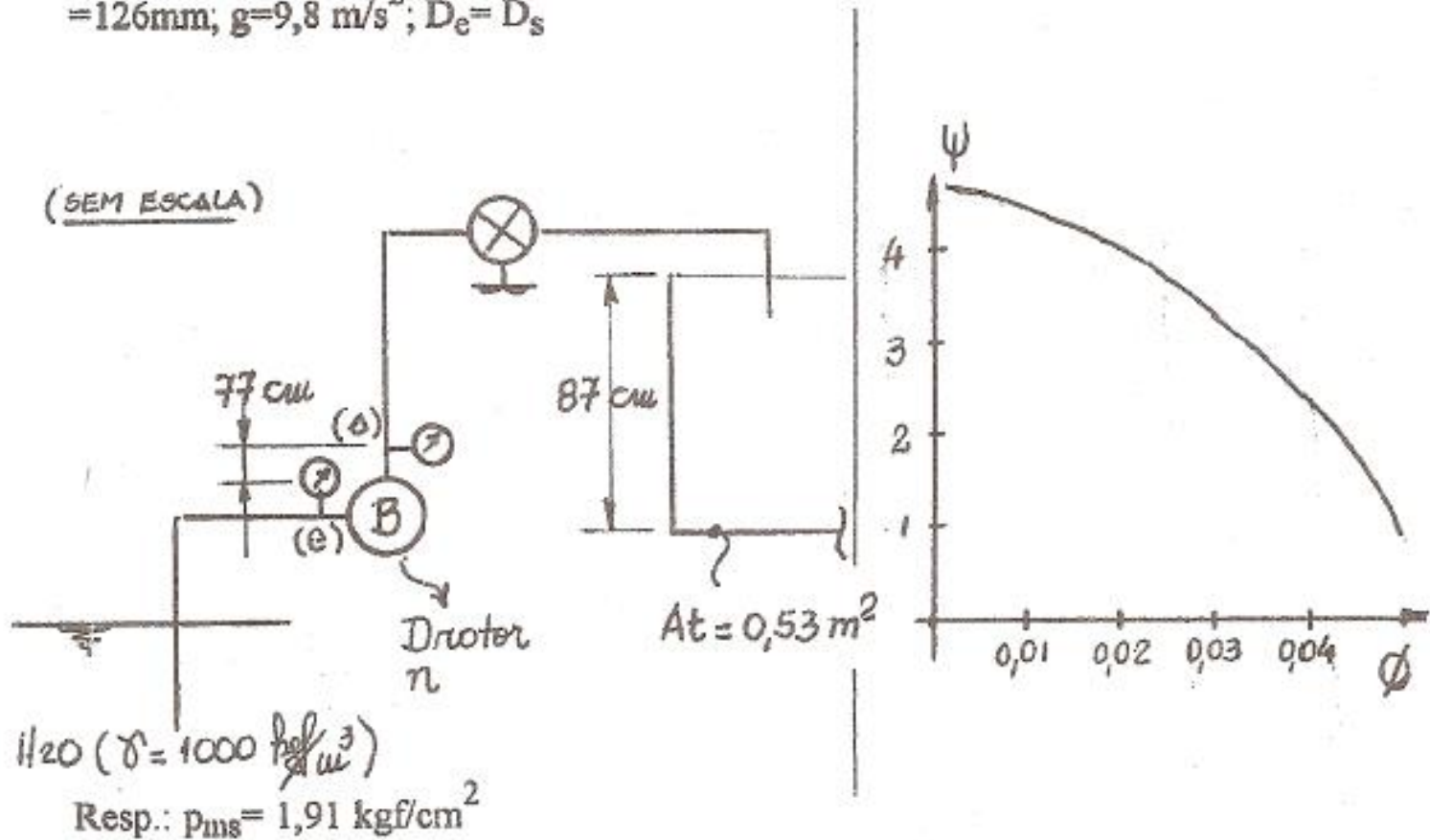

2

Sabendo-se que o tempo cronometrado para um $\Delta h = 15\text{cm}$ no tanque é 20s, determinar a leitura do manômetro de saída da bomba.

Resp.: $p_{ms} = 1,71 \text{ kgf/cm}^2$

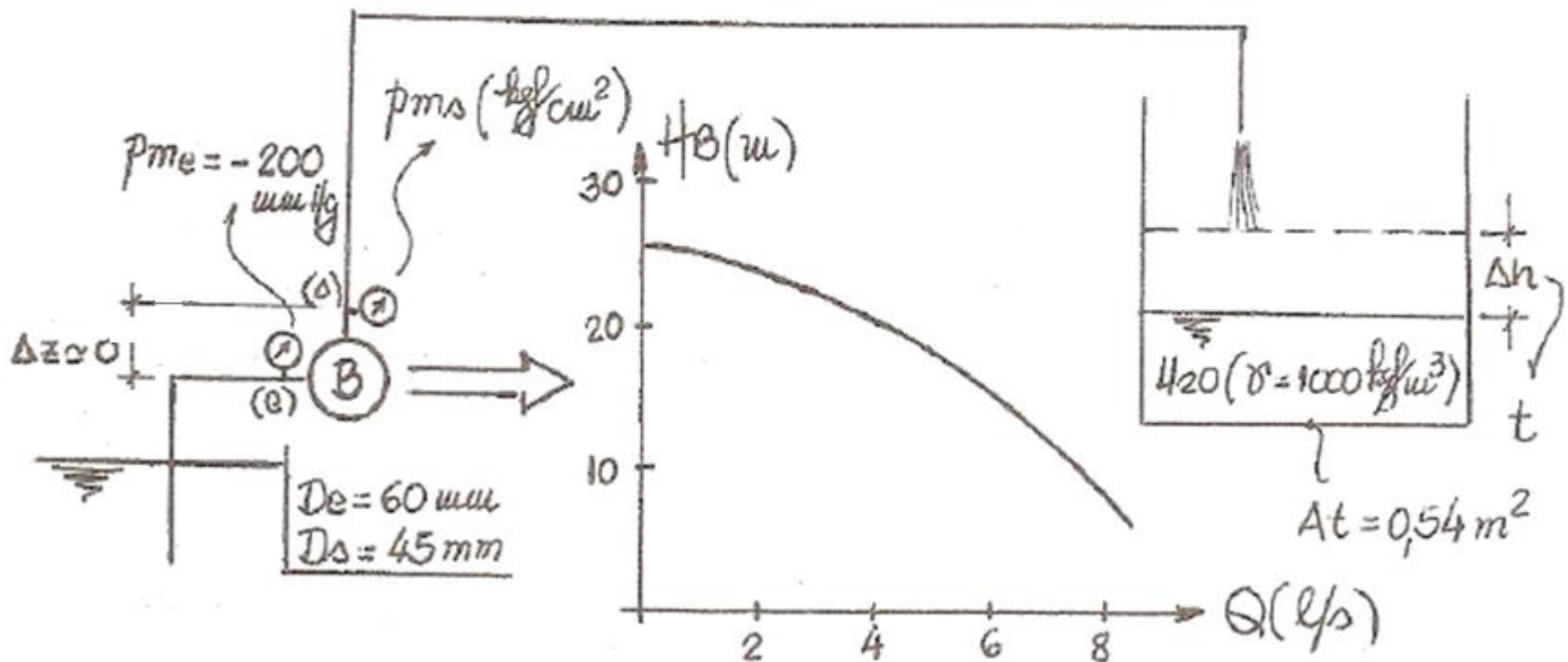

3

Um grupo realiza a Experiência de Reynolds no laboratório. A bomba, de curva universal conhecida, alimenta o tanque da figura, que permanece a nível constante. Sabendo-se que no ensaio o tipo de escoamento no tubo de vidro está passando para turbulento, determinar:

- a) a vazão fornecida pela bomba;
 b) o volume coletado no tubo graduado em 35s.

Resp.: a) 2,9L/s; b) 0,98L

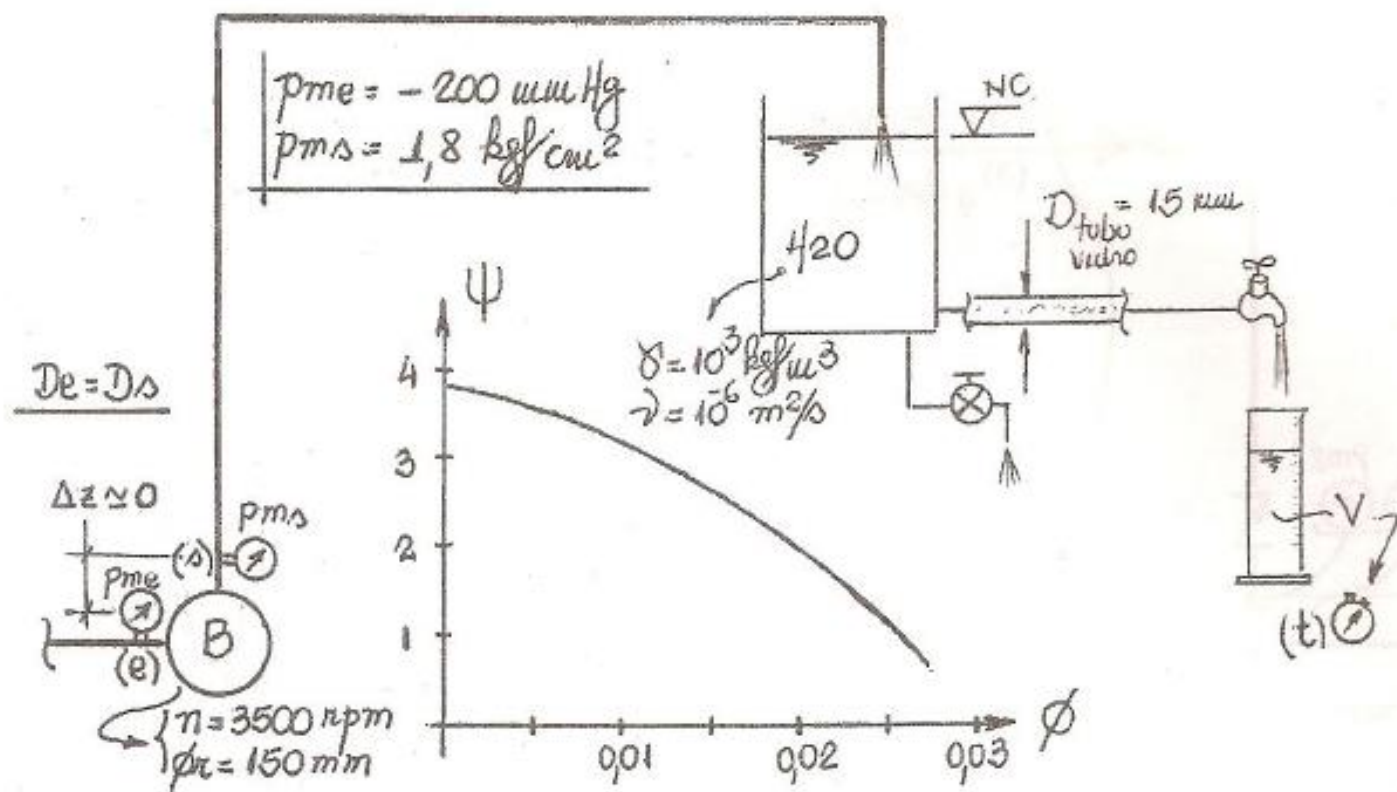

4

É dada a curva universal, válida para todas as bombas semelhantes à bomba da instalação da figura. Qual a leitura do manômetro (2) em kPa, quando um desnível de 15cm, no tanque de área da seção transversal de 2m^2 , é preenchido em 20s? Dados: diâmetro do rotor da bomba $D_R = 230\text{mm}$; rotação do rotor da bomba $n = 3600\text{rpm}$; $\gamma = 10000\text{N/m}^3$; $g = 10\text{m/s}^2$.

Se o registro for completamente fechado, qual a diferença de pressão entre a entrada e a saída da bomba?

Adimensionais de uma bomba: $\phi = \frac{Q}{nD_R^3}$; $\Psi = \frac{gH_B}{n^2D_R^2}$

